



Dusk to Dawn Photocell comes standard

Description

Altech's Security Series Wall Pack LED fixture is perfect for building perimeters and alleys for added security overnight. Simple and provides much-needed light in darkness.



Applications

Wet Environments	Tunnel Roads	Wall-side Pathways
Security Lighting	Alleyways	Underground Parking

Specs

Efficacy	130 lm/W
Input Voltage	100-277V
Finish	Black

Details

IP Rating	IP65
Materials	Aluminum
Lens	Anti-UV Polycarbonate Lens
L70 Life	150,000 Hours
Warranty	5 Years
CRI	80+
Qualification	UL, FCC, CE, RoHS
Chip Man.	Philips
Whip Length(ft)	2'

Electrical

Power Factor	0.99
Frequency	50/60 Hz
Max THD	15%
Operating Temp.	-40° F to 130° F -40° C to 54° C
Dimming	0-10V

LED WALL PACK SECURITY SERIES

Ordering Information

ORDERING #	Wattage	CCT	Lumens	Equivalent
U-IWP-15-30	15W	3000K	1,807 lm	70-100W MH
U-IWP-15-40	15W	4000K	1,875 lm	70-100W MH
U-IWP-15-50	15W	5000K	1,935 lm	70-100W MH

Additional Notes

- 4000K and 5000K, 100-277V are stocked locally, check for ETA's
- Altech Electronics reserves the right to make periodic improvements to our product specs

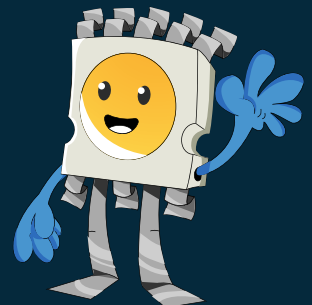

Installation

1. Disconnect all power sources
(VERY IMPORTANT).
2. Mount the back plate on the wall with the expansion screws.

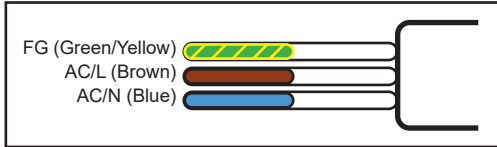

3. Wire the fixture appropriately.
Brown is live. Blue is neutral. Green/Yellow is ground.
4. Mount the fixture on the back plate.

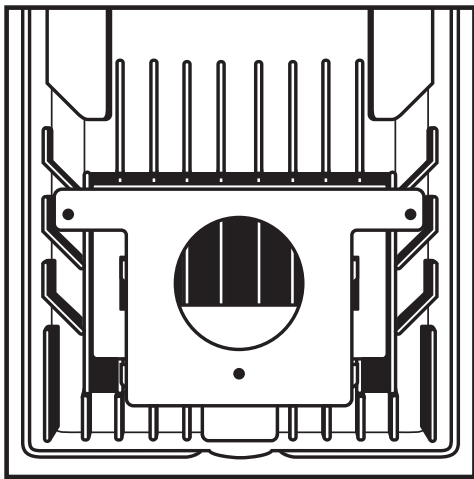

5. Installation Complete.

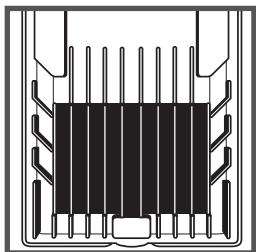

External heat sink designed especially for this wall pack. Not only does it extend the life span, but also makes it suitable for warmer locations.

Fixture Dimensions and Weight

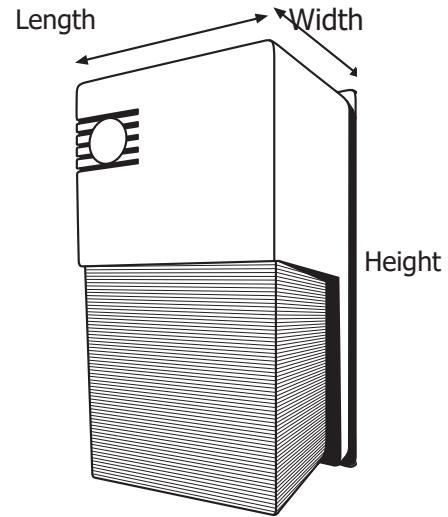

Length	Width	Height	Weight
5.5 in.	7.75 in.	13 in.	2.6 lb.
140 mm.	197 mm.	330 mm.	1.2 kg.

Accessories and Options



Compatible with controls and integrations



Phenix Internal Emergency Inverter (18470X-2) (optional)